

DIAMOND MANUAL

Installation, operation and maintenance manual (English Language)



Standard range:

Models DMS2 / DMS3 / DMS4 / DMS5
Models DMC6 / DMC7 / DMC8 / DMC9
Blower kiosk for DMS and DMC

Additional parts depending on site condition:

Invert extensions
Sample chamber
External pumping chamber

TABLE OF CONTENTS

STANDARD MODELS & ADDITIONAL PARTS	3
Health & Safety Precautions	3
Standard Models	7
Additional Parts	8
Invert extensions	8
DMS invert extensions	8
DMS factory-fitted body invert extension	8
DMC factory-fitted neck invert extension	9
Sample Chamber	9
External pumping chamber (EPC)	10
Non-factory fitted inverts:	11
DMS non-factory fitted neck invert extension	11
DMS & DMC - EPC non-factory fitted neck invert extension ring	12
Additional part to accompany a DMS-EPC	12
What is wastewater treatment?	13
Diamond range	13
HOW THE DIAMOND WORKS	14
Sizing Of The Plant Considerations:	15
Water softeners	15
Waste disposal units (WDU)	15
Grease from the kitchen	15
Condensing boilers	15
Surface run-offs/storm water	15
Swimming pool and hot tubs	15
DMS range	16
DMC range	17
Planning	18
Ground conditions	18
High water tables	18
Delivery to site	19
Inspection of goods	19
Diamond plant location	20
Pipework gradients	20
Blower kiosk	21
Venting options	21
Guide to equipment and material not supplied by WCS Environmental Engineering	21
Tank Installation:	22
Excavating the correct tank size trench	22
Backfilling instructions	22
Excavation guide	23
Groundworks	23
Base construction	23
Backfill material	23
Invert extensions	24
DMS body invert extensions	24
Non factory fitted DMS 460mm neck invert extension instructions	24
DMC neck invert extensions	25

BLOWER KIOSKS INSTALLATION	26
DMS blower kiosk.....	26
DMC blower kiosk.....	26
Blower motor size (kW) and power.....	27
DMS and DMC kiosk installation location.....	27
DMS kiosk.....	28
DMC kiosk.....	28
Connecting tank (DMS/DMC) to the kiosk.....	29
Hose connections.....	29
Blower kiosk electrics DMS/DMC.....	29
Sample chamber installation.....	30
OPERATION & MAINTENANCE	31
Operation	31
Start up.....	31
Maintenance	31
Tank de-sludge frequency.....	31
Determining de-sludging frequency.....	31
Procedure for de-sludging.....	32
Approximate de-sludge volumes guide.....	32
Blower kiosk maintenance.....	32
Sample Chamber.....	32
TROUBLESHOOTING	33
DMS and DMC range.....	33
External Pumping Chamber	35
DMS-EPC Models.....	35
Installation Considerations.....	36
Electrical installation.....	37
Start Up	38
Maintenance	39
Troubleshooting	40
Hints And Tips	41
PROCESS GUARANTEE & WARRANTY	42
Process guarantee.....	42
Parts covered under the warranty period.....	42
Warranty limitations/exemptions.....	42
Chargeable non-warranty work.....	43

This manual should be retained by the owner for the lifetime of the Diamond plant.

In the event of change of ownership, the manual should be transferred to the new owner.

The owner is responsible for the sewage treatment plant, ensuring that the effluent quality does not breach applicable discharge consent standards.

Please read this manual thoroughly before commencing with installation, operations and maintenance.

STANDARD MODELS & ADDITIONAL PARTS

HEALTH & SAFETY PRECAUTIONS

This section describes some of the potential risks and the ways in which they can be reduced. These guidelines do not set out or interpret the law – they are simply a guide to improve safety during the plant's lifecycle. The Principal Contractor and service companies should produce their own comprehensive health and safety plan.

What is sewage?

The term may be used to mean raw sewage, sewage sludge, or septic tank waste. Raw sewage is mainly water containing excrement, industrial effluent and debris, such as sanitary towels, condoms, plastic etc.

Protecting workers from risks to health

Since micro-organisms are an inherent part of sewage, the hazard cannot be eliminated so a proper assessment of risk is required. The Principal Contractor and service provider should produce a full risk assessment before starting work.

Sensible precautions

- Ensure you understand risks through proper instruction, training and supervision
- Seek professional guidance on inoculations that may be required
- Wear suitable Personal Protective Equipment
- Follow strict hand hygiene measures - clean water, soap, nailbrushes, disposable paper towels, and where heavy contamination is foreseeable, showers
- Clothing or boots contaminated with sewage must be washed thoroughly after use
- Parents should warn children of potential hazards

The following signage should be advised:



Civil Installation: Installation should only be carried out by qualified and experienced professionals who understand sewage and drainage systems and their obligations under the Health and Safety at Work Act, Construction Design Management (CDM) Regulations and the Environmental Protection Act. Where necessary they should seek advice from a civil engineer.

Electrical work: Electrical works must be carried out safely and securely by a qualified electrician in accordance with the engineering standards.

Servicing & maintenance: WCS Environmental Engineering recommends a British Water Accredited service engineer when dealing with harmful micro-organisms.

De-sludging & frequency: De-sludging should be carried out by professionals holding the relevant permits to transport and dispose of sewage sludge.

They will also be able to advise the correct de-sludge frequency by analysing the percentage of settled sludge (i.e. sludge volume) to the clear liquor.



Sampling: WCS Environmental Engineering recommends sampling to be undertaken by a British Water Accredited service engineer. Samples can be taken from a sample chamber or an external pumping chamber.



Dangerous gasses inside the tank: Sewage gases are potentially explosive and toxic. Do not enter any of the below ground compartments of the sewage treatment plant.

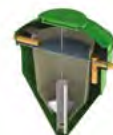

Delivery to site:

If there are overhead electrical cables, ensure that there is adequate clearance or that the power is turned off. If there are any obstructions to site delivery, please contact WCS Environmental Engineering to advise in advance. Installer must carry out a detailed Lift Plan prior to commencing work.

WCS Environmental Engineering deliver to the closest hard standing suitable for a lorry or trailer. If the nearest road access for a heavy goods vehicle is not adjacent to the site, it is the responsibility of the contractor/purchaser to arrange transport from the road to the site. WCS Environmental Engineering accepts no responsibility for the selection of lifting equipment.

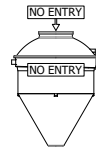
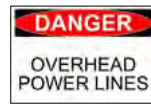

Not designed for pedestrian walkways/ traffic drive-over:

The plant lid is tested with a load at 1.0Kn/m² and will withstand accidental passage. Lids are not designed for use on pedestrian walkways. Do not allow machinery or traffic to drive over the plant.



Lifting the tank:

Do not lift the treatment tank without first draining the water inside.

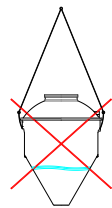

Tank installation:

Do not use vibrating pokers.

Increasing invert extension height:

Only one 460mm extension can be fitted to a Diamond tank. Do not stack with an additional invert extension as this will adversely affect the warranty and serviceability of the unit, as well as being a Health and Safety consideration for access.

Tank cover:

Do not leave the plant cover open for any longer than is strictly necessary. Temporary barriers and warning signs should be erected around any open covers or manways as appropriate.



**Blower kiosk
– surface water:**

Do not allow surface water to form a pool around the access lid or blower housing.

**Additional parts
- factory fitted:**

Please specify at point of order if factory fitted parts such as invert extensions and an External Pumping Chamber (EPC) are required.

Delivery inspection:

Off-loading will only be performed at the nearest hardstanding to site that is suitable for heavy goods vehicles. Inspect goods for damage before placing on the ground. If damage is identified on delivery, WCS Environmental Engineering must be notified within 24 hours. Do not attempt to carry out any unauthorised repairs, as this will invalidate the warranty on the goods supplied. Once installed, WCS Environmental Engineering cannot accept any claims for damage.

Blower kiosk installation:

Any void left underneath the blower kiosk will amplify the noise of the blower.

Blower kiosk maintenance:

Please refer to the specific instruction manual supplied with the air blower. Warranty is subject to the manufacturer's instruction.

Maintenance logbook:

All service and maintenance for the Diamond plant must be recorded in the logbook provided.

STANDARD MODELS

Standard tank models DMS2, DMS3, DMS4 and DMS5 come supplied with:

- Tank as specified x1
- Tank lid with M10 x 50mm stainless steel hex bolts x2
- Weatherproof kiosk x1, comes with a low air pressure alarm beacon and blower inside
- 10m of $\frac{3}{4}$ inch hose with hose clips x2, for the blower



Standard tank models DMC6, DMC7, DMC8 and DMC come supplied with:

- Tank as specified x1
- Tank lid with M10 x 50mm, stainless steel hex bolts x2
- Weatherproof kiosk x1, comes with a low air pressure alarm beacon and blower inside
- 10m of $\frac{3}{4}$ inch hose with hose clips x2, for the airline from the blower outlet to the tank air diffuser



ADDITIONAL PARTS

Depending on site conditions, DMS and DMC models may be supplied with an invert extension and or external pumping chamber (EPC).

Please specify on order if you require any additional factory-fitted parts such as invert extensions and external pumping chambers.

INVERT EXTENSIONS

DMS Invert Extensions:

Standard factory-fitted body invert extension heights of 700mm or 1000mm.

For a shallow extension where the factory-fitted option is too great, a non-factory fitted neck invert extension (height is 460mm), can be supplied loose and cut to size on site.

If supplied with a factory-fitted invert and a deeper invert is required, please contact WCS Environmental Engineering or your supplier

DMS factory-fitted body invert extension:

Standard factory-fitted body invert extension height options:

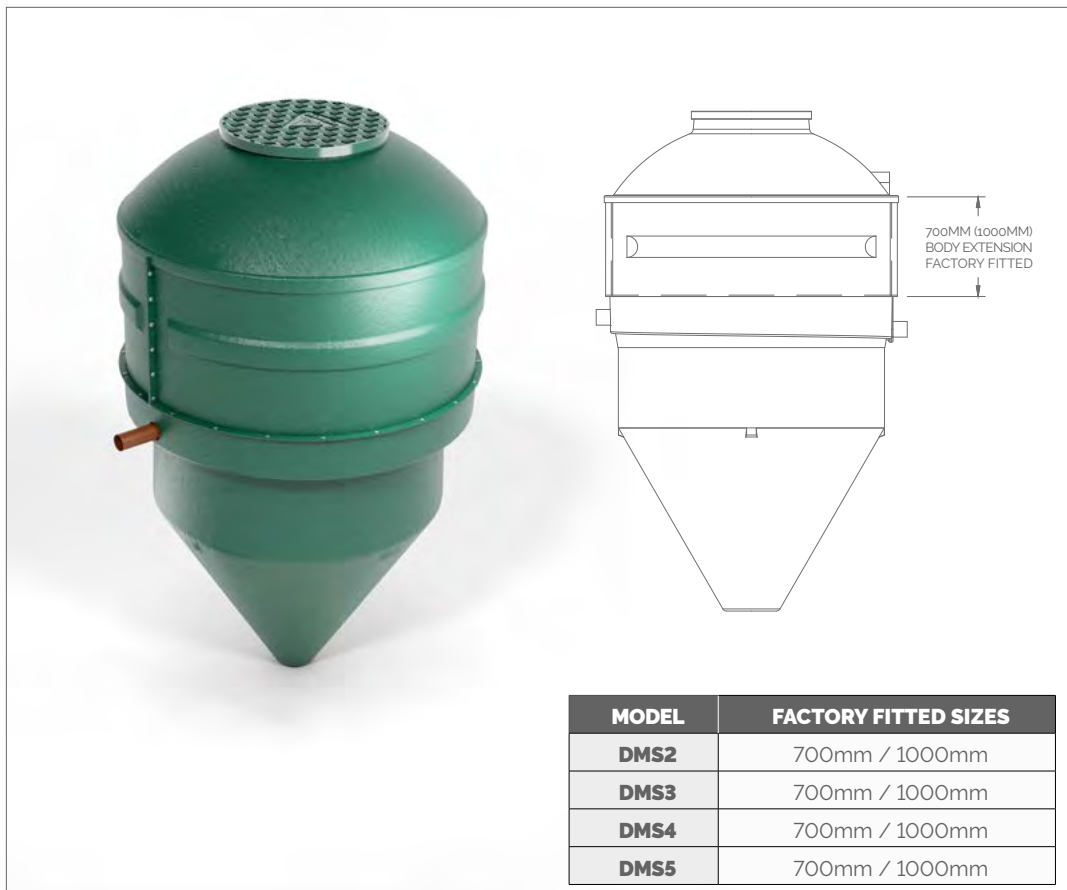

DMC factory-fitted neck invert extension:

Standard factory-fitted neck invert extension available in heights:
300mm, 600mm,1000mm.

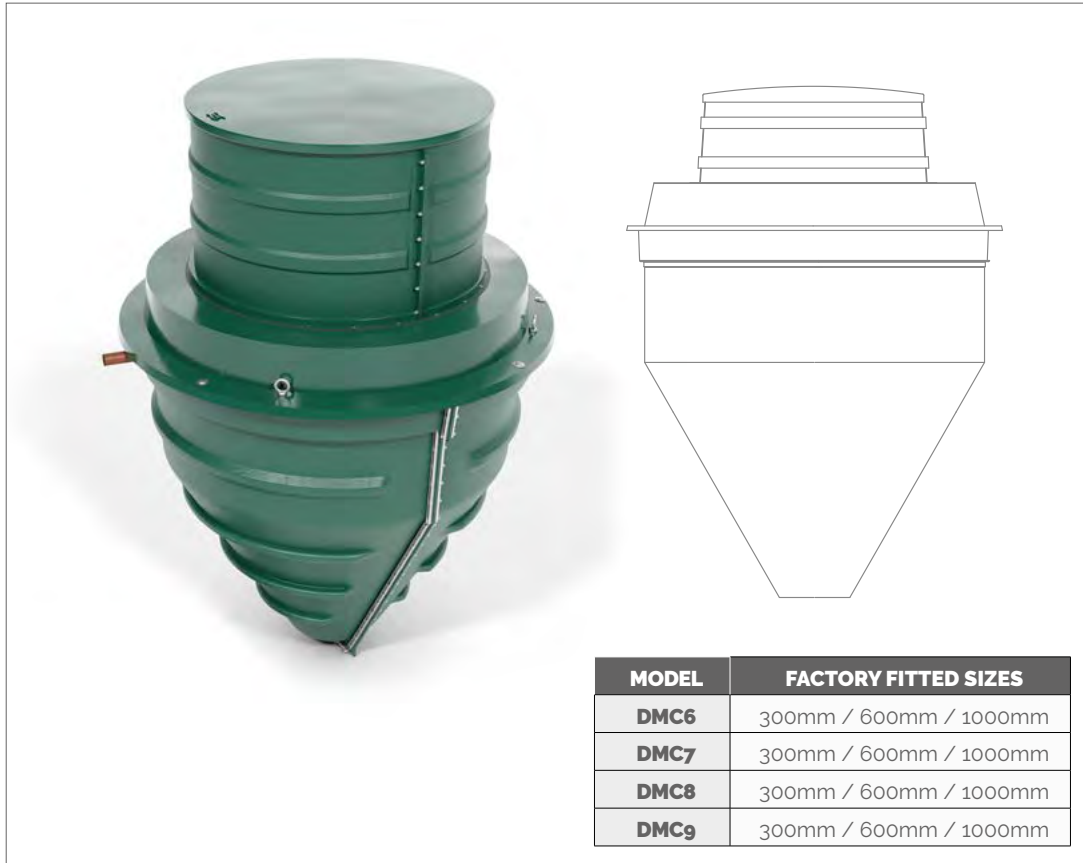

Sample Chamber:

WCS Environmental Engineering recommends installing one for ease of access to retrieve samples.

The sample chamber comes supplied with 250mm removable inspection hatch x1.



External pumping chamber (EPC)

If a deeper factory-fitted invert extension is required, please specify on order.

The EPC also has the added benefit of being used as a sample chamber.

The EPC comes supplied with:

- Pumping chamber x1
- Manhole cover x1
- High level float switch x1
- Submersible pump and integral float switch x1
- Non-return valve
- Isolation valve
- 32mm MPDE pipe outlet fitting
- Electrical junction box
- Installation handles
- Red, flashing high level alarm beacon as fitted on the kiosk



NON-FACTORY FITTED INVERTS

DMS non-factory fitted neck invert extension:

When on site and a deeper invert is required, you can order a 460mm invert neck extension which can be cut down to the required height. Only one 460mm extension can be fitted to the tank - do not stack with an additional neck invert extension. If in doubt please contact WCS Environmental Engineering for further installation advice.

The neck invert extension is supplied with:

- 450mm $\frac{1}{2}$ PVC pipe
- $\frac{1}{2}$ " PVC sockets x2
- Diffuser pipe support bar
- Plastic push fittings for tree fixings x3

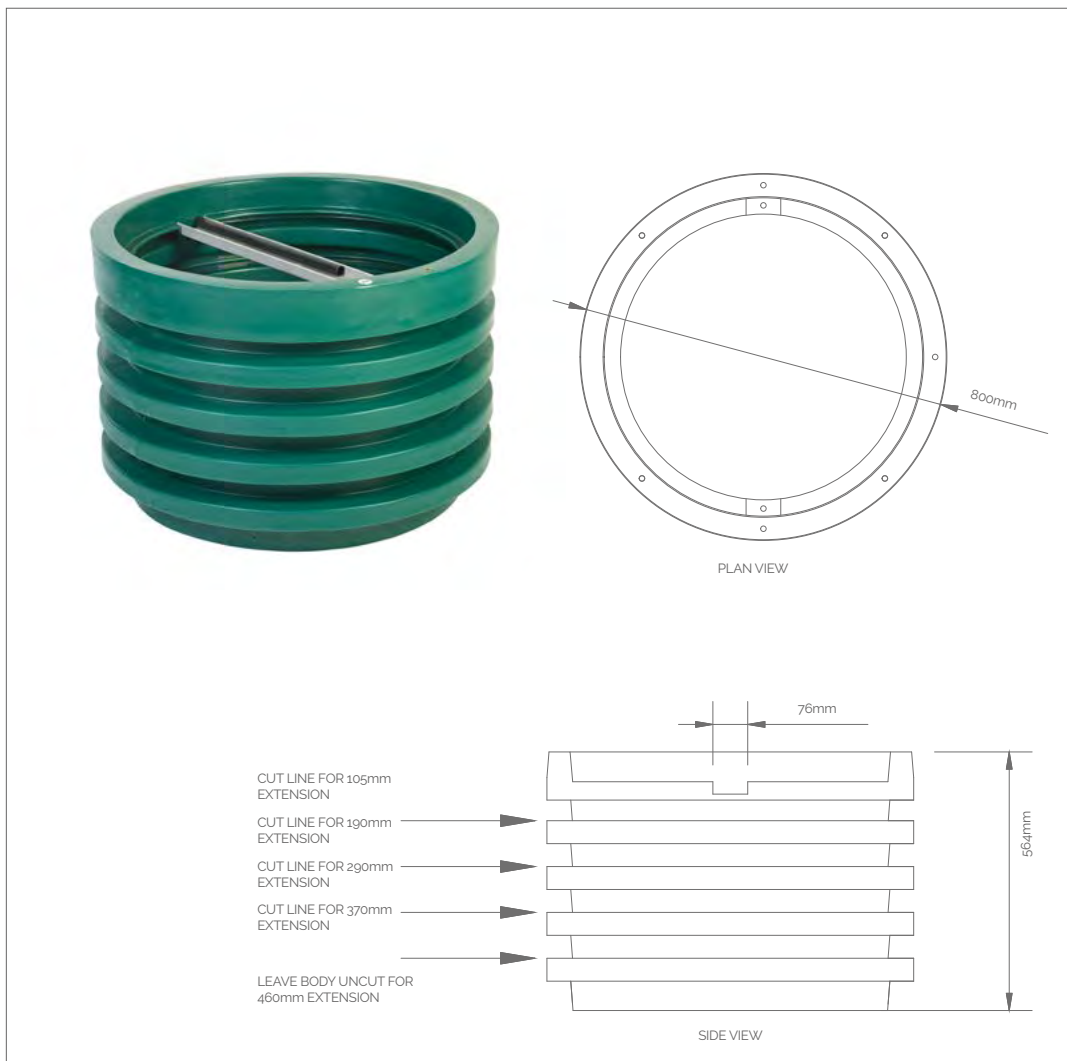

DMS AND DMC - EPC non-factory fitted neck invert extension ring:

When on site and a deeper EPC invert is required - 215mm x 2 extension rings are available to order. This is to accompany a non-factory fitted 460mm DMS neck extension. Only one 460mm extension can be fitted to the tank - do not stack with an additional neck invert extension.



Additional part to accompany a DMS-EPC:

EPC adapter Kit.



Please contact WCS Environmental Engineering for full listing of authorised service kits and spares.

WHAT IS WASTEWATER TREATMENT?

Wastewater treatment, also known as sewage treatment, is the process of removing contaminants and suspended solids from primarily household and commercial property waste such as toilets, showers and sinks.

DIAMOND RANGE

The Diamond compact package wastewater (sewage) treatment plant is suitable for domestic and small commercial properties in all ground conditions where mains drainage is unavailable. With both UK and European patents, the Diamond range is also BS EN12566-3 2014 approved.

The compact range has the flexibility to be configured to meet the needs of various population sizes. The DMS tank supports 1 up to 20 population equivalent (PE) and the DMC tank supports 21 up to 50 population equivalent (PE). Both can be installed in 'wet' or 'dry' ground conditions, discharging to soakaways or watercourses.

The standard package includes a Diamond tank, kiosk, alarm beacon, blower (housed in a kiosk) and a 10 metre air hose. OEM additional parts based on site condition are available – including external pumping chamber (EPC), invert extensions and sample chamber.



HOW THE DIAMOND WORKS

Unlike the traditional septic tanks, this modern packaged wastewater treatment plant is designed with an aerated process for today's increased volume of water usage in everyday life.

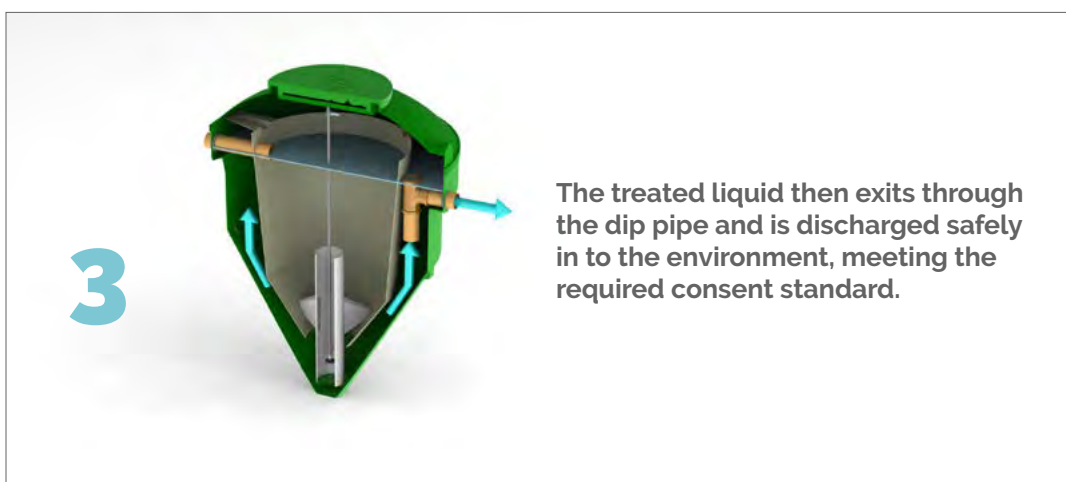
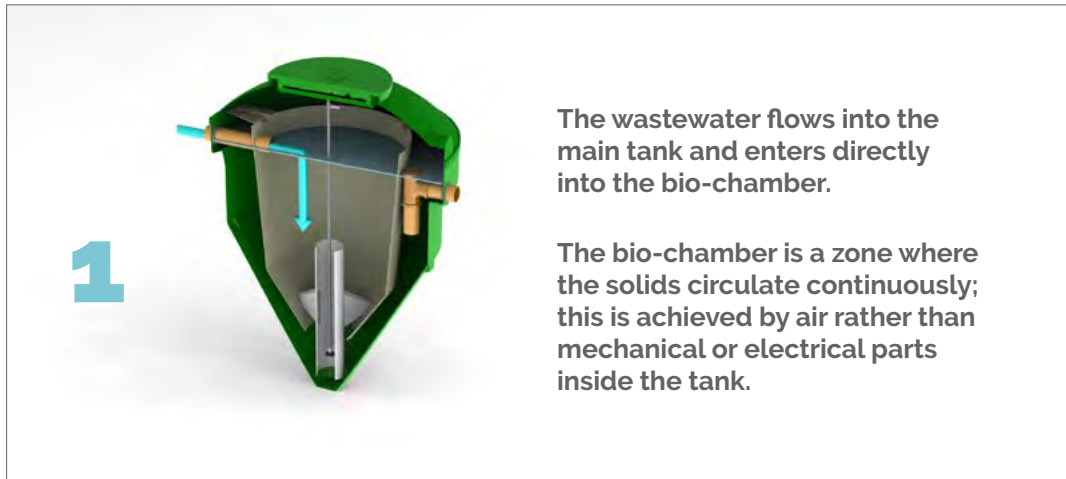

Watch how the process works [How the Diamond compact wastewater treatment plant works:](#)

[How the Diamond compact wastewater treatment plant works](#)

SIZING OF THE PLANT CONSIDERATIONS

Water softeners

Salt based water softeners can significantly reduce bacteria growth in the treatment plant and negatively affect its performance. An existing softener can be used but regeneration should be minimised and the quality of discharge monitored. A non-salt based softener should be used where possible. If you are installing a new unit where one did not exist previously, seek advice from your British Water accredited service technician provider first.

Waste disposal units (WDU)

The treatment plant should have been sized taking into account the use of a WDU in the property (if there is one installed) as this will increase biological loading. It is advisable to limit the use of the WDU to ensure the WCS Environmental Engineering Diamond treatment plant operates efficiently. Raw or uncooked foods should not be put through the WDU and ideally disposed of in a composter. If an existing WDU unit was not included in the sizing of the treatment plant, then it is advised that the WDU is not used nor installed subsequently in the property.

Grease from the kitchen

The treatment plant should be protected from grease and fats if installed in a property or commercial premises where catering is provided. All commercial catering applications require the installation of adequately sized grease separators, removal or retention systems up-stream of the treatment plant. It is advisable to check that this provision has been made prior to installing the treatment plant.

Condensing boilers

Discharge from condensing boilers should ideally be connected to a separate drainage field if possible.

Surface run-offs/storm water

The treatment plant should never be connected to guttering and drainage that collects stormwater and/or surface water run-off from hard standings and surfaces. Do not allow storm water from roofs or hard standings to enter the treatment plant. Surface/stormwater should always be discharged to a storm drain which is excluded from the wastewater stream from the property.

Swimming pool and hot tubs

The treatment plant should never be connected to swimming pools or hot tubs as they contain bacteria inhibiting chemicals that will significantly reduce the performance of the treatment plant.

Use a separate treatment for disposal of backwash waters from ancillary equipment such as filtration and disinfectant.

The WCS Environmental Engineering Diamond range is based on a population equivalent. However please ensure that the plant been sized to suit requirements using the current British Water Flows and Loads codes of practise.

DMS range

Model	Population	Max Outside Diameter	Height to Inlet	Inlet Invert Depth	Height to Outlet	Max Height/ In Ground Depth	Weight Empty	Total Capacity
		(A)	(B)	(C)	(D)	(E)	(KG)	(L)
DMS2	1-6	1740	1700	630	1610	2330	155	2270
DMS3	5-11	1960	1830	760	1730	2590	192	3030
DMS4	10-15	1990	2000	780	1930	2780	210	3975
DMS5	14-20	1990	2000	780	1930	2780	210	3975

• Dimensions above shown in mm
 • Deeper inverts can be accommodated with our range of standard invert extensions.
 • Indicative technical drawing only

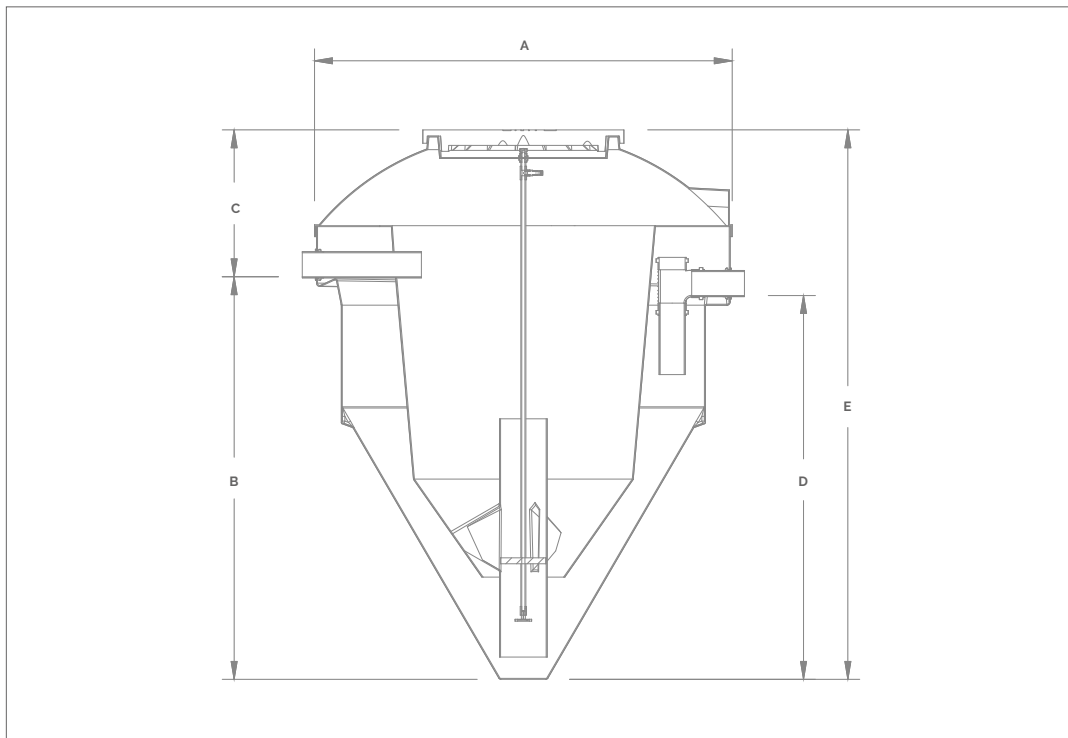

DMS kiosk power consumption				
Model	Blower Type	Power per blower (kW)	No. of Blowers	Kiosk Power Consumption (kW)
DMS2	JDK80C	0.050	1	0.06
DMS3	JDK100C	0.075	1	0.08
DMS4	JDK150C	0.115	1	0.12
DMS5	JDK200C	0.180	1	0.19

Model	Population	Max Outside Diameter	Height to Inlet	Inlet Invert Depth	Height to Outlet	Max Height/ In Ground Depth	Weight Empty	Total Capacity
		(A)	(B)	(C)	(D)	(E)	(KG)	(L)
DMC6	21-27	3300	2780	570	2680	3350	380	9056
DMC7	28-35	3300	2780	570	2680	3350	380	9056
DMC8	36-45	3300	3140	580	3040	3750	460	15038
DMC9	46-55	3300	3140	580	3040	3750	460	15038

- Dimensions above shown in mm
- Deeper inverts can be accommodated with our range of standard invert extensions
- Indicative technical drawing only

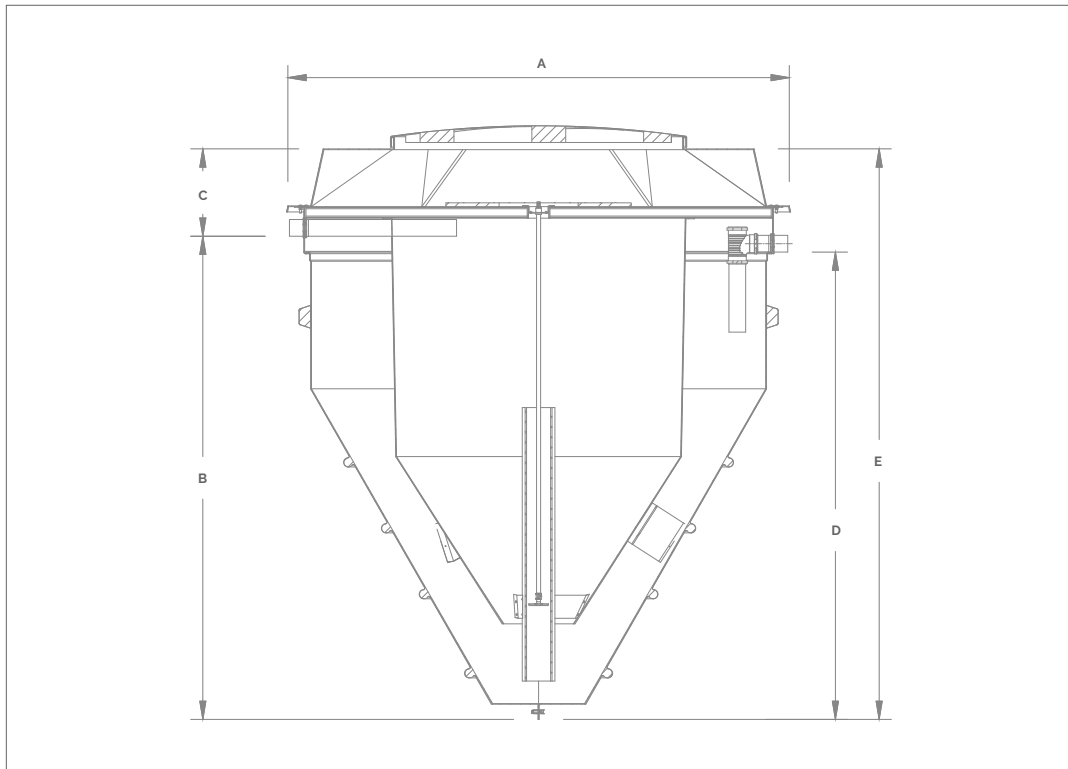

DMC kiosk power consumption					
Model	Blower Type	Power per blower (kW)	No. of Blowers	Min Power Consumption (kW)	Max Power Consumption (kW)
DMC6	3D19T-050-0.37	0.37	1	0.27	0.37
DMC7	3D19T-050-0.55	0.55	1	0.37	0.55
DMC8	3D19T-050-0.55	0.55	1	0.37	0.55
DMC9	3D19T-050-0.55	0.55	1	0.37	0.55

Planning

Please ensure all necessary permissions have been sought and granted and ensure that due consideration/ appropriate action has been given/ taken regarding the following:

- Planning Permission, Building Regulations, and other regulating or interested parties
- Environment Agency, SEPA or Natural Resources Wales requirements
- The size of the plant is in line with the British Water Flows and Loads codes of practise

Ground conditions

Ground conditions and water table level should be assessed before installation. Please ensure local ground conditions are suitable for the installation by assessing the following factors at your installation site:

- Risk of high water table or flooding
- Underground rivers, running sand and chemicals in the soil
- Proximity of designated protection areas such as:
 - wells, bore holes, and springs used as sources of potable water
 - existing non-mains sewage systems and soakaways
 - water courses, ponds and lakes
 - other services, pipes, cables and ducts
- Sites which are close to trees (particularly willows) or shrubs considering root proof membrane

High water tables

Installing in an excavation that allows water to enter the plant, has a high ground water table or is susceptible to flood conditions will cause problems during installation and may affect the plant during de-sludging.

For installations in a high water table or clay soiled areas, backfill with a dry-lean concrete mix to approximately 150mm below the lid.

Contd..

Delivery to site

Off-loading will only take place at the nearest hard standing to site that is suitable for heavy goods vehicles. If damage is identified on delivery, WCS Environmental Engineering must be notified within 24 hours.

If the nearest road access for a heavy goods vehicle is not adjacent to the site, it is the responsibility of the contractor/purchaser to arrange transport from the road to the site. When lifting the unit, use webbing slings of a suitable specification, which must be attached to the designated lifting points. WCS Environmental Engineering accepts no responsibility for the selection of lifting equipment.

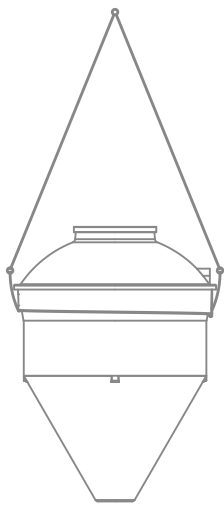

Inspection of goods

- Inspect goods for any damage before placing on the ground
- Do not attempt to carry out any unauthorised repairs
- The goods should be placed on level ground with no sharp stones or bricks as they may cause damage
- Electrical equipment must be stored in dry, condensation free conditions until required

If there are electrical cables overhead, ensure that there is adequate clearance or the power is turned off.



The Diamond plant location

The Diamond plant must be sited:

- Within 30 metres of heavy vehicle access for de-sludging
- As far from the habitable parts of the dwelling as possible. Many local authorities recommend allowing a minimum of 7 metres, but easements are possible for smaller sites subject to local planning approval. Please check with your local authority about the General Binding Rules

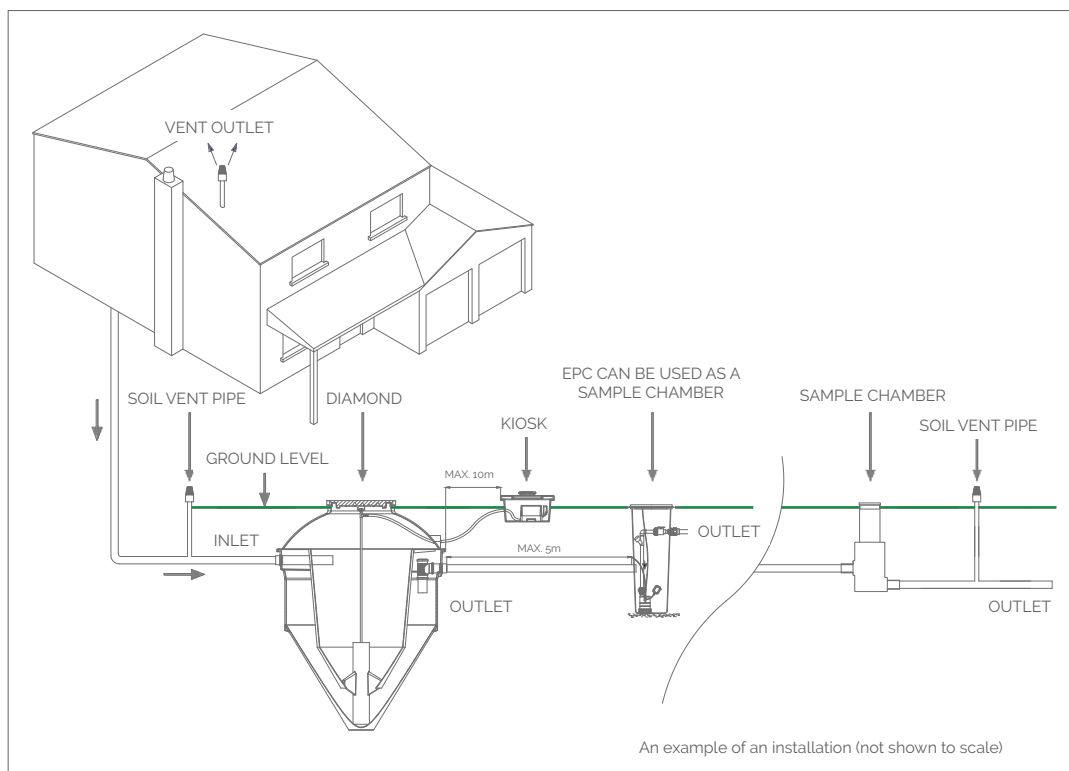

Tested with a load at 1.0Kn/m² to withstand accidental passage, tank lids are not designed as pedestrian walkways.

Pipework gradients

- Ensure that there is sufficient fall (gradient) from the dwelling to give a self-cleansing velocity that prevents blockages in the pipes
- Drainage field pipework to be constructed as per building regulations

Blower kiosk

- Ideally located 5-10m from the tank
- Ensure beacons are visible – this will aid prompt detection of operational failures
- Choose a shaded northerly aspect with easy access for maintenance. Avoid direct sunlight, vegetation/plant overgrowth, dust and flood water
- Consideration must be given as to the siting of the kiosk to reduce any potential disruption caused

Venting options

- See illustration on page 20 for ventilation options

Guide to equipment and material not supplied by WCS Environmental Engineering

- Excavator - sufficient reach to attain the depth required, along with webbing slings for lifting the plant
- Hose duct pipework - rigid or flexible to contain and protect the air pipework going from the kiosk to the tank
- Pipework vents
- An electrical cable, armoured or ducted - 2.5mm 2 twin and earth
- IP55 rated outdoor double socket with RCD x1
- 3-pin plug fused, rated at 13 amps (UK only) x1
- Tube of acrylic or polyurethane mastic x1
- Expanding polyurethane foam - to seal hose and ducts x1
- Silkaflex to seal the neck invert extension (if applicable) x1
- Dry lean concrete mix to backfill the tank x 1
- Sharp sand or dry, lean concrete mix to backfill the blower kiosk

TANK INSTALLATION

Excavating the correct size trench

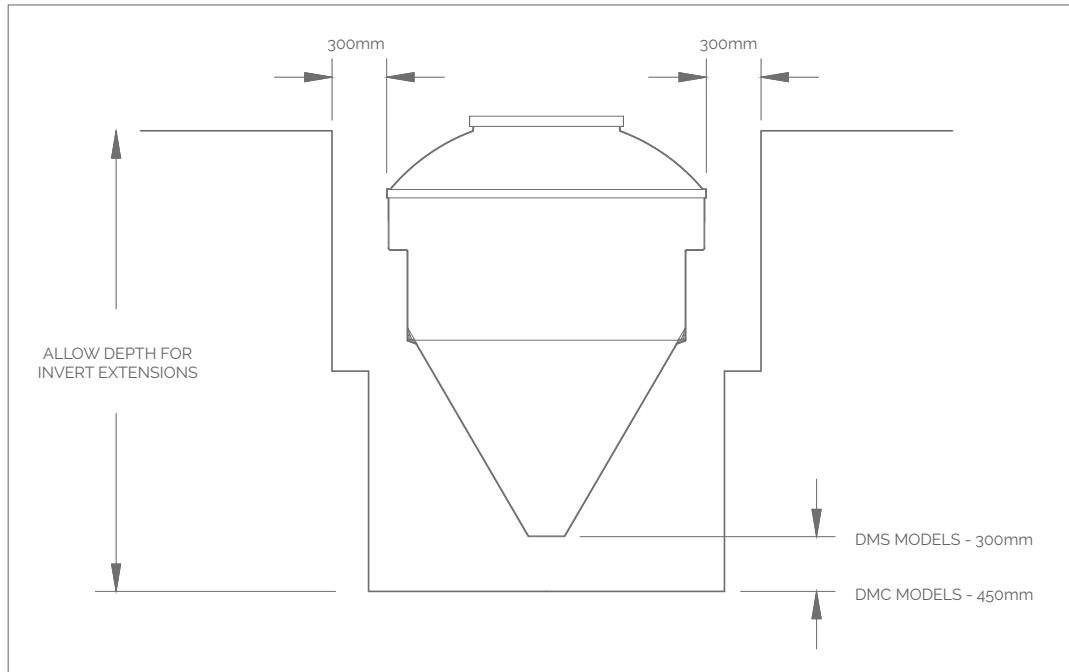

A square stepped excavation may be used due to the physical shape of the Diamond plant. Allow adequate clearance for all pipes and any other connections to the unit.

Do not attempt to lift the treatment tank when filled with water.

Backfilling instructions

The tank should be backfilled as per the installation diagram. Regular checks must be performed during backfilling to ensure the tank remains level.

Contd.

Excavation guide

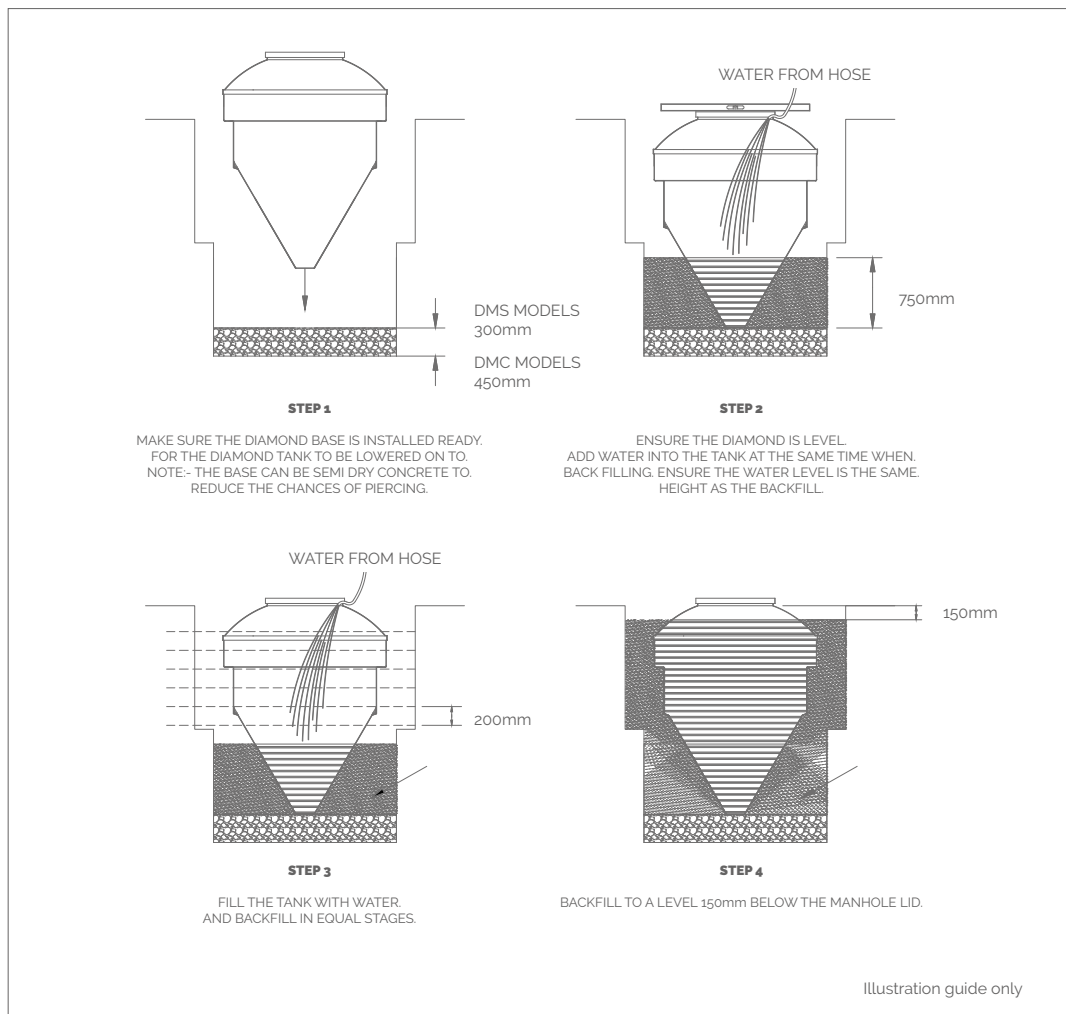

Groundworks

A square stepped excavation may be used due to the physical shape of the Diamond plant. Allow adequate clearance for all pipes and any other connections for the tank.

Base construction

Both the base on which the tank sits and the backfill material must support the tank when full to prevent it from sinking.

Backfill material

WCS Environmental Engineering recommends using dry-lean concrete to approximately 150mm below the tank lid.

Under no circumstances should the backfill material be vibrated to achieve compaction. Do not use vibrating pokes. Also, the backfill pour must not outpace the ballasting of the tank with water. Backfill outside can only equal the level of the water inside.

1: EXTENSION OPTIONS

The Diamond plant may be supplied factory fitted with an optional invert extension (either as a turret or body extension on DMS models, or as a turret extension on DMC models) if specified when ordered.

If the plant has been supplied with the standard invert and a deeper invert is required, please contact WCS Environmental Engineering or your supplier as these can be supplied and fitted on site.

Body Extensions Dimensions

Only available on DMS models in sizes from 200mm to 1000mm, in 100mm increments.

Do not stack turret extensions to increase the invert as this will adversely affect the serviceability of the unit.

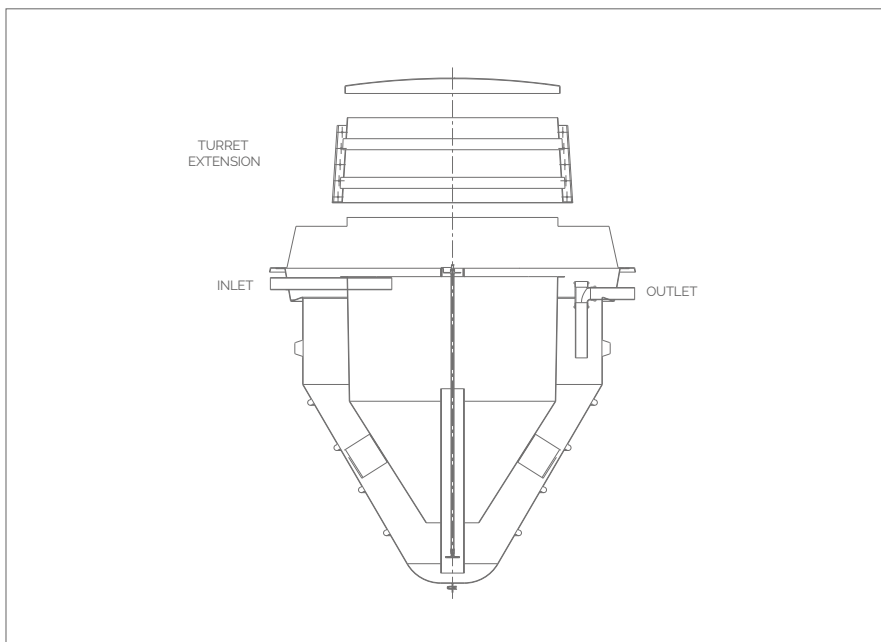

DMS2 & DMS3	DMS4 & DMS5	DMC6-9
190mm	200mm	100mm increments up to a maximum of 1200mm
280mm	300mm	
370mm		
460mm		

2: DMS/DMC TURRET INVERT EXTENSION FITTING INSTRUCTIONS

- 1) Remove the access lid.
- 2) Remove the diffuser air leg from the bar, undo the threaded cap first, then undo the threaded tank connector.
- 3) Drop the diffuser pipe down so it's clear from the support bar and lift clear of the tank.
- 4) Cut away the green support bar from each edge near the flange of the turret.

-
- 5) Place the extension turret over the diamond turret, and with a spirit level, make sure it is level.
 - 6) Mark holes ready to be drilled (using the turret extension as a guide) and drill 7mm holes and using the black plastic fir tree connectors, fix the turret to the Diamond.
 - 7) Place the grey support bar in the top of the turret.
 - 8) With the new diffuser pipe, position it in the centre of the tank and measure from the bottom of the Diamond up to the underside of the support bar then take away 150mm from this figure, the new figure will be the overall total measurement for the diffuser leg to the top of the bottom nut on the tank connector. Cut the pipe to match the new measurement then glue the sockets and pipe together.
 - 9) Take the existing diffuser leg and measure down 50mm from the bottom of the tee and cut. (Save the Tee connection).
 - 10) You will need to use PVC glue). Glue one of the sockets on the end of the extension pipe, then glue the second socket onto the opposite end of the extension pipe.
Leave for 10 mins.
 - 11) Then glue the long part of the diffuser leg into one of the socket ends.
Leave for 10 mins.
 - 12) Then glue the tee and tank connector to the other end of the diffuser extension.
Leave for 10 mins.
 - 13) Drop the diffuser pipe into the centre of the tank, making sure the leg is inside the white tube towards the bottom of the diamond.
 - 14) Bring the tank connector through the new support bar. Tighten the large nut so the diffuser leg is not loose.
 - 15) Place the threaded cap on the top of the tank connector.
 - 16) Connect the hose to the brass hosedetail and secure a firm grip using the clamp provided.
 - 17) Apply a bead of sealant where the turret and dome cover meet.
 - 18) Replace the lid and secure with the thumb bolts.
 - 19) Backfill 150mm below the turret edge.

3: DMS BODY INVERT EXTENSION FITTING INSTRUCTIONS

Assemble the two halves of the body extension using the nuts, bolts and washers supplied and seal the vertical joint with a bead of sealant.

Place the extension on top of the main body and gently clamp together. Drill eight equally spaced holes around the joining flange and secure with the nuts bolts and washers supplied.

Place the dome cover, complete with lid, on top of the extension. Using the already drilled holes as a guide, drill through the top flange of the extension and refit the eyebolts.

BLOWER KIOSK INSTALLATION

Each Diamond comes with its own weatherproof kiosk, complete with an air blower, low air pressure alarm beacon, 10m of hose and two (2) hose clips.

Make sure the air blower is installed in a dry, well ventilated area. If it is situated outside, ensure it is installed in the approved, weatherproof housing supplied with the Diamond plant.

DMS blower kiosk

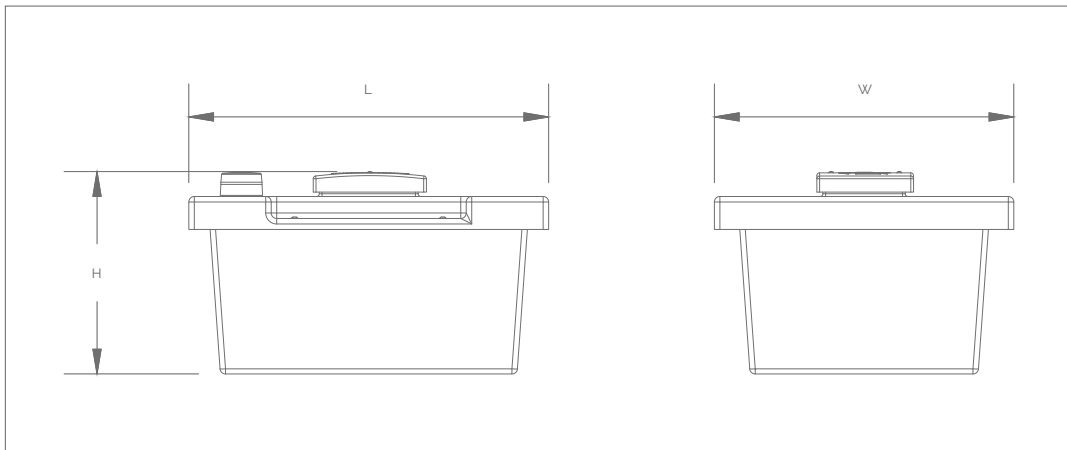

- (L) 655mm x (W) 545mm x (H) 366mm
- Kiosk weather protection rated to IP54

DMC blower kiosk

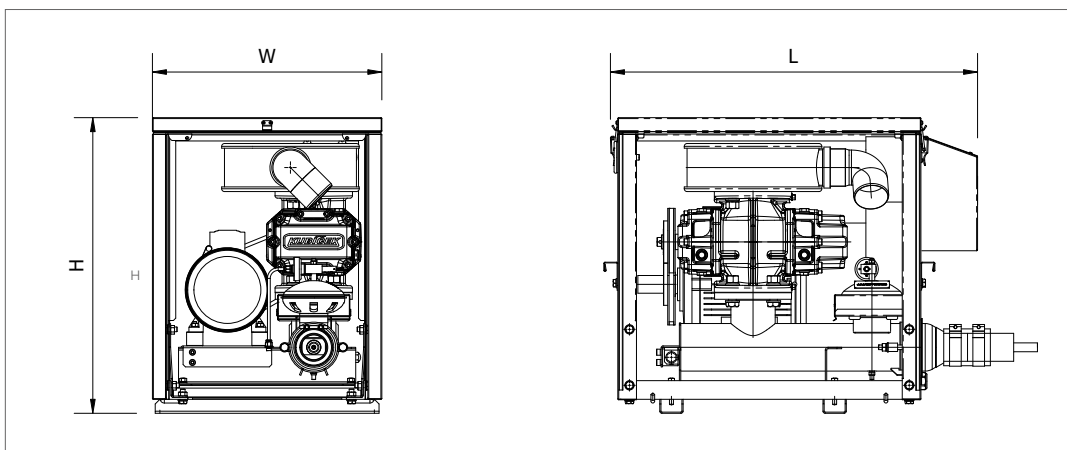

- (L) 790mm x (W) 495mm x (H) 635mm
- Kiosk weather protection rated to IP54

DMS kiosk power consumption

Model	Blower type	Blower consumption (kW)	Kiosk consumption (kW)
DMS2	JDK80C	0.050	0.060
DMS3	JDK100C	0.075	0.080
DMS4	JDK150C	0.115	0.120
DMS5	JDK200C	0.180	0.190

DMS and DMC kiosk installation location

- Select a location for the blower kiosk ideally 5-10m from the tank in a shaded northerly aspect with easy access for maintenance. Avoid positioning the kiosk in direct sunlight, overgrown vegetation which obstructs the view, or where it may be exposed to dust and flood water.
- Ensure the alarm beacon can be seen if there is a failure of any kind.
- Air is provided to the tank continuously by a small blower housed in a kiosk which is positioned near the tank

Do not allow surface water to form a pool around the access lid or blower housing.

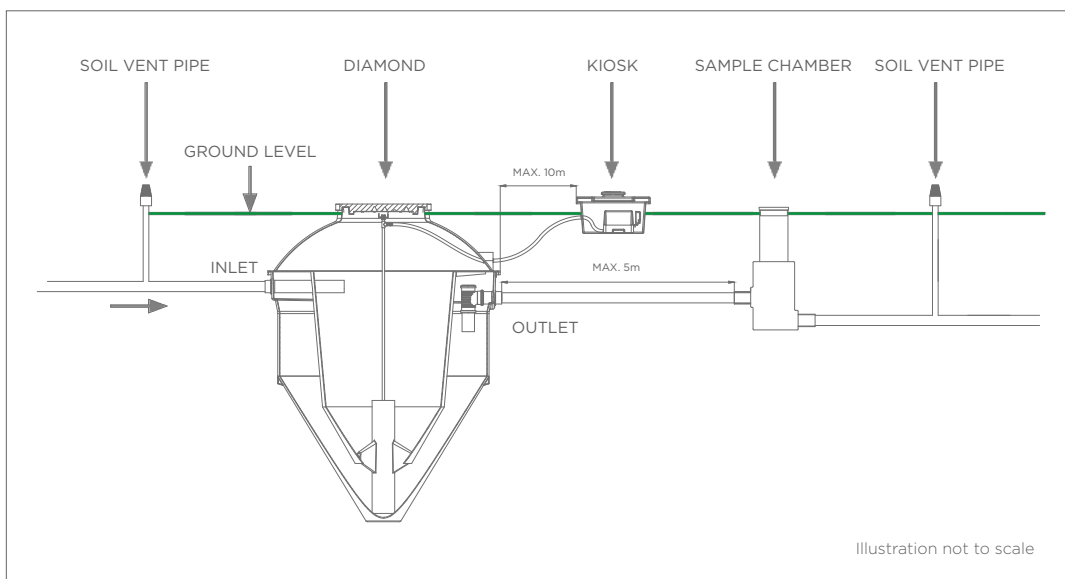

DMS kiosk

The DMS kiosk is designed to be partially submerged in the ground (to a depth of 200mm), although it can be mounted above ground if the owner prefers.

- Dig a hole approximately 100mm wider than the kiosk dimensions and approximately 200mm deep
- Put a 50mm layer of sand, sharp sand or dry lean mix concrete in the bottom of the hole and bed the kiosk onto it, ensuring that there is not a void underneath
- Backfill around the kiosk with sand, sharp sand or dry lean mix concrete

Any void left underneath the blower kiosk will amplify the noise of the blower.

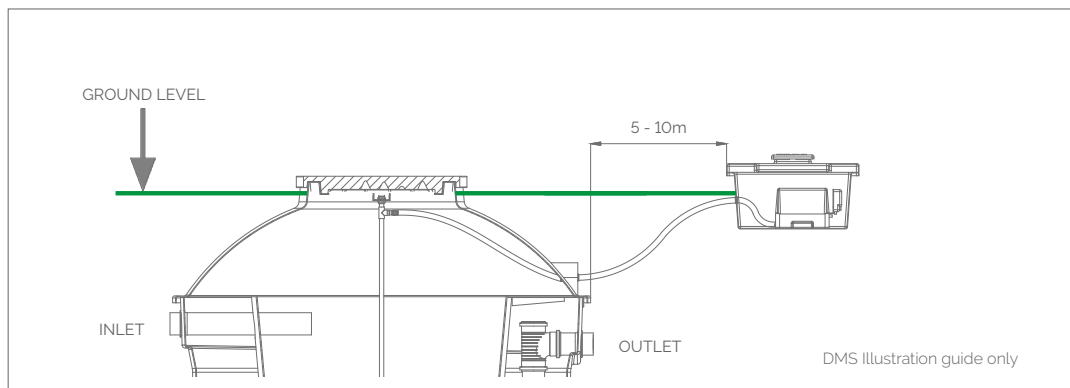

DMC kiosk

The DMC kiosk is for above ground installation only and should be mounted on a concrete plinth or hard standing.

- Ensure the kiosk position is not at risk of flooding
- Lay a concrete base slab, or hard standing to match the blower kiosk size
- Once the concrete is fully cured, secure kiosk to the slab through the Unistrut and seal to the concrete with mastic.

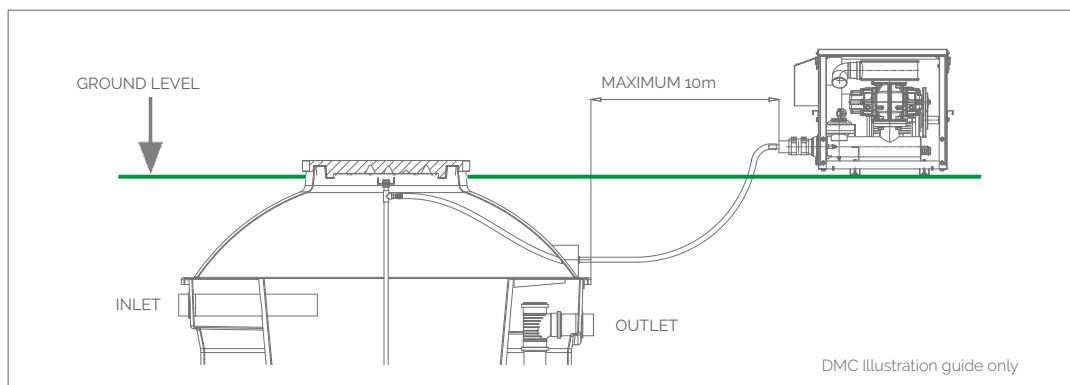

Connecting tank (DMS/DMC) to the kiosk

- Dig a narrow trench to a depth of approx. 500mm, from the tank to the site of the blower kiosk and lay the hose duct in it
- Lay ducting from the kiosk to the mains power supply
- DMS only - cut a hole the diameter of the duct in either the bottom or the side of the blower kiosk and pass the duct through the hole
- Feed the hose through the duct
- Apply a 10mm bead of mastic / silicon sealant inside and out to stick the duct to the kiosk
- Allow the sealant to cure
- Ensure no water can enter into the kiosk through the duct
- Cut / drill another hole for the entry of the electrical cabling or ducting

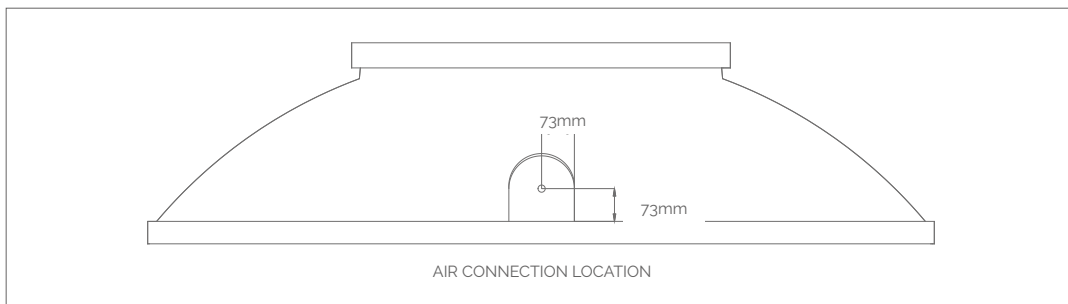

Hose connections

- Connect and secure the hose to the hose tail on the air distribution pipe in the centre of the tank with the hose clip supplied
- Ensure there are no kinks in the lines
- Cut the hose to length, connect to the hose tail on the blower in the kiosk and secure with the hose clip supplied
- The hose must run in a straight line to ensure the air supply is not disrupted

Blower kiosk electrics DMS/DMC

- An earth leakage circuit breaker is recommended and should be incorporated into the supply
- A device with a 30mA maximum trip current is recommended
- Blowers are supplied with single phase electrics as standard

Blower DB rating datasheets are available on request.

Sample chamber installation

The sample chamber routes all outgoing flow (treated effluent) from the tank. There is a drop within the chamber to ease obtaining a sample, accessible from the 250mm removable inspection hatch.

The sample chamber should be:

- Positioned no further than 5m away from the outlet of the tank
- Installed with dry-lean concrete mix up to 300mm below ground level

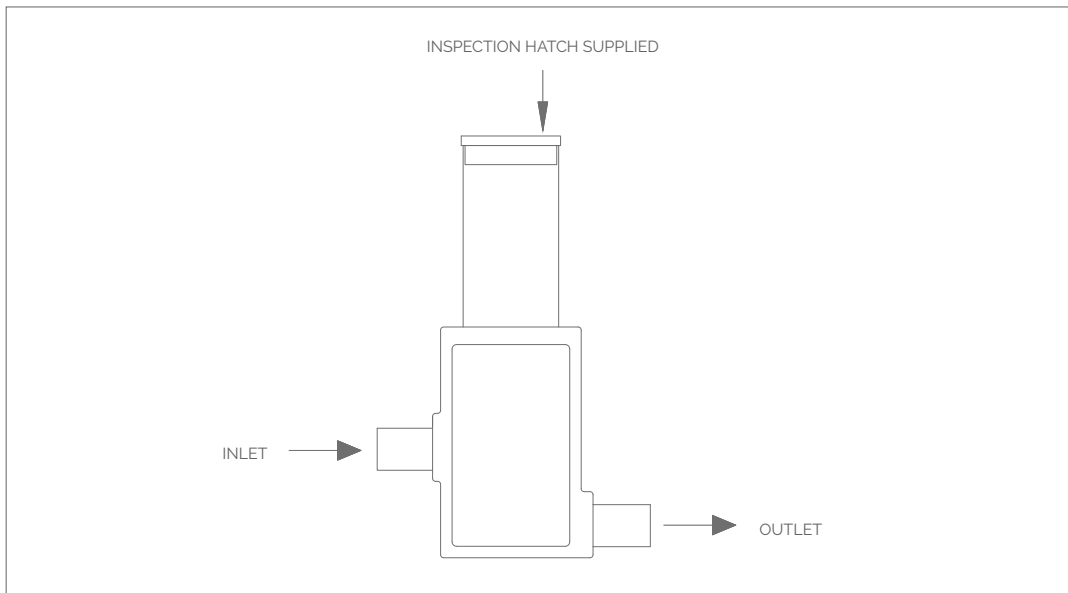

You can gain samples from an External Pumping Chamber (EPC). You do not require a sample chamber if an EPC is being fitted.

OPERATION & MAINTENANCE

Authorised service kits and spare parts are supplied by WCS Environmental Engineering.

Service and maintenance advice is available from WCS Environmental Engineering.

All service and maintenance for the Diamond plant must be recorded in the logbook provided.

OPERATION

It is important that the sewage input conditions are kept within the plant design criteria, including the population equivalent (British Water Flows and Loads practises).

Start up

The plant is designed to operate automatically with the minimum of maintenance after it has been commissioned. The plant will provide effluent within the designed discharge content standard after the initial start-up period of 4-10 weeks, depending on the water temperature.

There may be an odour whilst the plant is going through the start-up period.

MAINTENANCE

The Diamond plant requires routine, periodic inspection and maintenance to ensure continuous, trouble-free operation. At a minimum, the tank should be inspected every six months by a British Water Accredited Service Engineer. See logbook for details.

More frequent inspections may be required if mandated by local or national regulatory authorities, or if the tank is used in a non-residential application.

Tank de-sludging frequency

- DMS range de-sludging period can be up to 3 years depending on plant loading
- DMC range de-sludging period can be up to 12 months depending on plant loading

Determining de-sludging frequency

This should be provided by a British Water Accredited Service Engineer who will check the percentage of settled sludge (i.e. sludge volume) to the clear liquor.

The optimum level of solid settlement is normally between 5-50%. Whenever the sludge volume reaches 70%, the plant should be de-sludged.

Procedure for de-sludging

De-sludging must be carried out by an approved sewage treatment tanker company.

Approximate de-sludge volumes guide

Model	App. De-sludge Volumes (litres)	The amount of sludge accumulated depends on the loading of the plant. Each site has its own characteristics.
DMS2	1500	
DMS3	2100	
DMS4	2650	
DMS5	2650	
DMC6	6000	
DMC7	6000	
DMC8	10000	
DMC9	10000	

Blower kiosk maintenance

Please refer to the specific instruction manual supplied with the air blower. Warranty is subject to the manufacturer's instructions.

Weekly check:

- Air blower within the kiosk is operational
- Blower should be running, which can be heard externally, and the air failure beacon should NOT be flashing
- If the beacon is flashing this indicates that the air blower is not delivering air to the plant

Quarterly check:

- If in a location with prevailing temperature, dust and humidity conditions, check air blower filter cleanliness and clean or replace the filter as necessary.

Six-monthly check - visual inspection of:

- Air blower inlet filter
- Kiosk is dry and clear of any leaves
- Aeration chamber and air diffuser has an even bubble pattern
- Clarifying chamber has a minimum build-up of floating scum
- External pumping chamber (if fitted), outlet sample chamber (if applicable) all need to be checked and maintained as necessary

Yearly Action:

- Oil to be changed every year with full synthetic oil SAE 5W/40

Sample chamber

To retrieve samples, remove the small lid on top. This should be undertaken by a qualified service provider.

TROUBLESHOOTING

DMC & DMS RANGE

A - SYMPTOM	B - CAUSE	C - REMEDY
<p>1. Air blower is running but little or no turbulence is observed in aeration chamber</p> <p>This could be due to insufficient air supply to the aeration chamber, caused by one or more of the reasons opposite:</p>	1. Blocked air diffuser	1. Disconnect air pipe at the union and clean or replace air diffuser
	2. Blocked air hose or pipe	2. Inspect hose and pipe for blockages, especially at joints. Unblock as necessary
	3. Leaking hose or pipe joints	3. Inspect all hose and pipe joints and tighten as necessary
	4. Kinked, crushed or split air hose or pipe	4. Inspect and replace as necessary
	5. Excessively worn carbon vanes in Rotary Vaned Air Pump (DMC only)	5. See specific air blower manual
<p>2. Aeration chamber contents have a greyish (dishwater) appearance</p>	6. As B 1-4	6. As C 1-5
<p>3. Noticeable odour & poor effluent quality</p>	7. As B 1-4	7. As C 1-5
<p>4. Aeration chamber contents are grey/brown to black. Slight to strong septic odour. Effluent quality is poor and grey. Air blower is running and good turbulence is evident</p>	8. Heavy hydraulic surge flows from laundry or kitchen activities	8. For commercial applications install wa surge tank before the Diamond plant
		9. For residential applications, reduce the frequency of laundry to 1-2 loads per day
<p>5. Aeration chamber has a clear appearance with very few suspended solids (<5%). White suds observed. Effluent is clear with no odour.</p>	9. Light loading resulting in total digestion of solids	10. No action required if effluent quality is acceptable. Typical of intermittent use.
<p>6. Aeration chamber as 5, but with very fine particles in the effluent causing it to appear turbid or murky</p>	10. See B 8	11. See C 8-9

A - SYMPTOM	B - CAUSE	C - REMEDY
7. Aeration chamber contents have a grey appearance and slightly septic odour	11. System is lightly loaded and has been in use for less than 3 months	12. Continue start-up regime of minimal laundry and minimal cleaning chemicals.
		13. See C 1-5
	12. Insufficient organic matter present in the influent resulting in a slow start-up	14. "Seed" plant with WCS Environmental Engineering Formula 33 to help initiate start-up
	10. See B 8	15. See C 10
8. Aeration chamber contents are grey to black. Effluent is grey and has a strong septic odour	14. Organic overload due to excessive use of waste disposal unit	16. Refrain from discharging food scraps, grease, oil, etc into the waste disposal
	15. As B 1-4	17. As C 1-5
9. Grease balls are observed in the aeration chamber contents	16. Excessive kitchen waste and detergent	18. As C 8-9
	17. As B 1-4	19. As C 1-4
	18. Insufficient Dissolved Oxygen (DO)	20. At the time of a peak flow, turn air blower off for 15 minutes and check DO with a metre. If DO is less than 1.0 part per million, contact WCS Environmental Engineering for assistance
10. Effluent sample contains brown suspended solids, more noticeable during peak flow periods	19. Heavy build-up of mixed liquor suspended solids (MLSS), due to normal, long-term usage	21. De-sludge the Diamond plant
	20. Excessive (>125mm) scum has accumulated in the clarifying chamber. The scum is being carried under the scum baffle	22. Remove scum back to aeration chamber with a scoop
11. System requires de-sludging on a more frequent basis	21. Excessive use of powdered laundry detergent	23. Use liquid detergents or "concentrated" powders
12. Effluent sample contains excessive suspended solids. Aeration chamber contents have a normal chocolate brown colour, but sludge settles slowly in a jar and forms a light floc	22. Overabundance of "filamentous" bacteria that prevent compaction and settling of the sludge	23. Contact WCS Environmental Engineering for specific recommendations
13. Alarm beacon flashing	23. Blower motor tripped out probably caused by diaphragm failure	23. Replace diaphragms

EXTERNAL PUMPING CHAMBER

DMS-EPC MODELS

The DMS EPC is factory-fitted; please ensure you order with the Diamond plant.

The EPC has been developed to provide a means of delivery for treated effluent where the existing terrain and invert levels of the pipework prevent normal gravitational discharge. The unit delivers up to 100litres/minute of effluent. The EPC can also be used as a sample chamber.

EPC technical specification

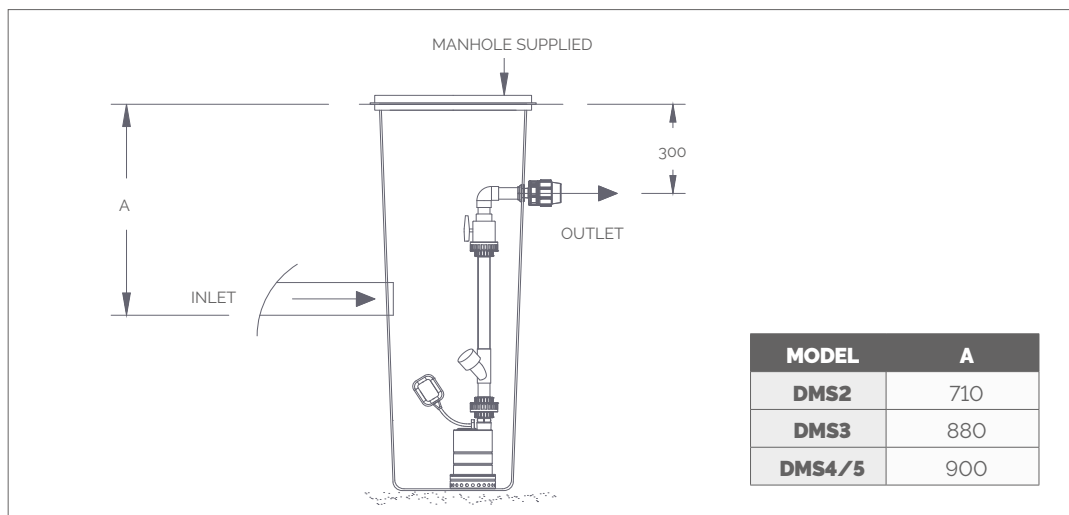

Whats included:

- Pumping chamber
- Manhole cover
- High level float switch
- Submersible pump and integral float switch
- Non-return valve
- Isolation valve
- 32mm MPDE pipe outlet fitting
- Electrical junction box
- Installation handles
- Red flashing high level alarm beacon on the kiosk

In the event of operational failure the EPC high-level alarm will start flashing.

INSTALLATION CONSIDERATIONS

- Consider the high-water table when installing the EPC. Seek advice from WCS Environmental Engineering.
- Excavate a hole 600mm in diameter and 1550mm deep
- When deeper invert levels are required, chamber extensions are available on request
- Level the base of the trench with concrete (not supplied), roughly 50mm deep
- Carefully lower the chamber into the hole, drop the straps on the outside of the chamber and insert the tank outlet pipe into the chamber inlet hole
- Backfill around the pumping chamber with concrete up to the lip of the chamber. Cover so no water enters the chamber and allow to fully set
- Concrete used must be the same as the backfill for the tank
- Lower pump into chamber
- Adjust the float switch cable so during floatation, the switch is 100mm below the pump chamber inlet
- Place the manhole hatch on top of the pumping chamber so it is level with the ground, seal the edges with concrete and allow to fully set

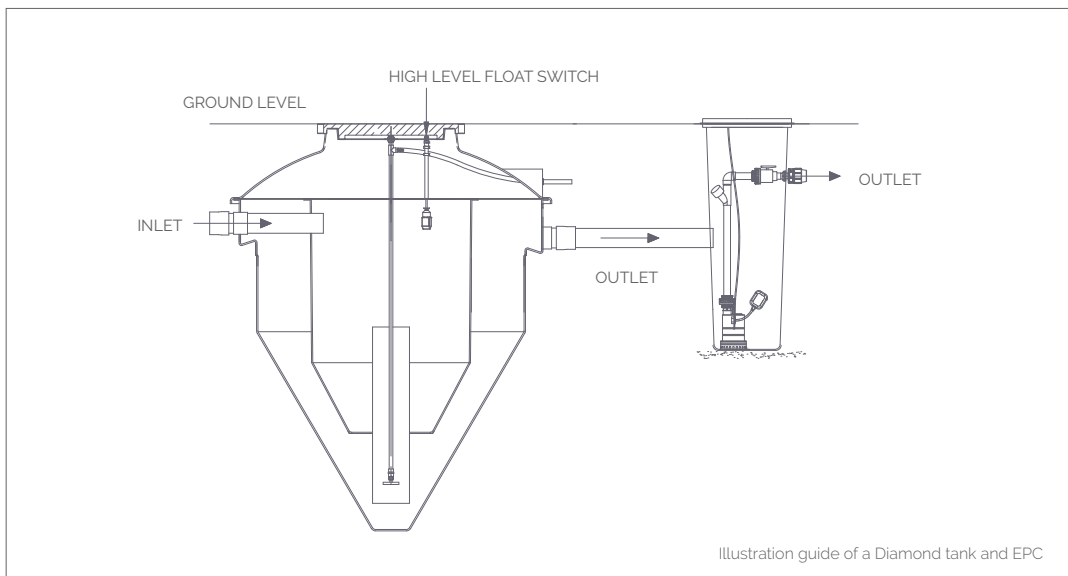

ELECTRICAL INSTALLATION

- Electrical connection should be made via its own dedicated supply
- Install a suitable conduit/pipe to carry all wires from the kiosk and high-level alarm float switch
- Run a draw line through the conduit/pipe
- Tie the draw line to the cables and pull the cables through the fittings, into the conduit/pipe and through to the blower kiosk
- Connect the float switch (for the high-level alarm) to the junction box
- Plug the flying lead from the red beacon into the junction box
- Connect the mains supply from an RCD protected power supply and turn on
- Image below shows the wiring layout inside the junction box
- Consider the high water table when installing

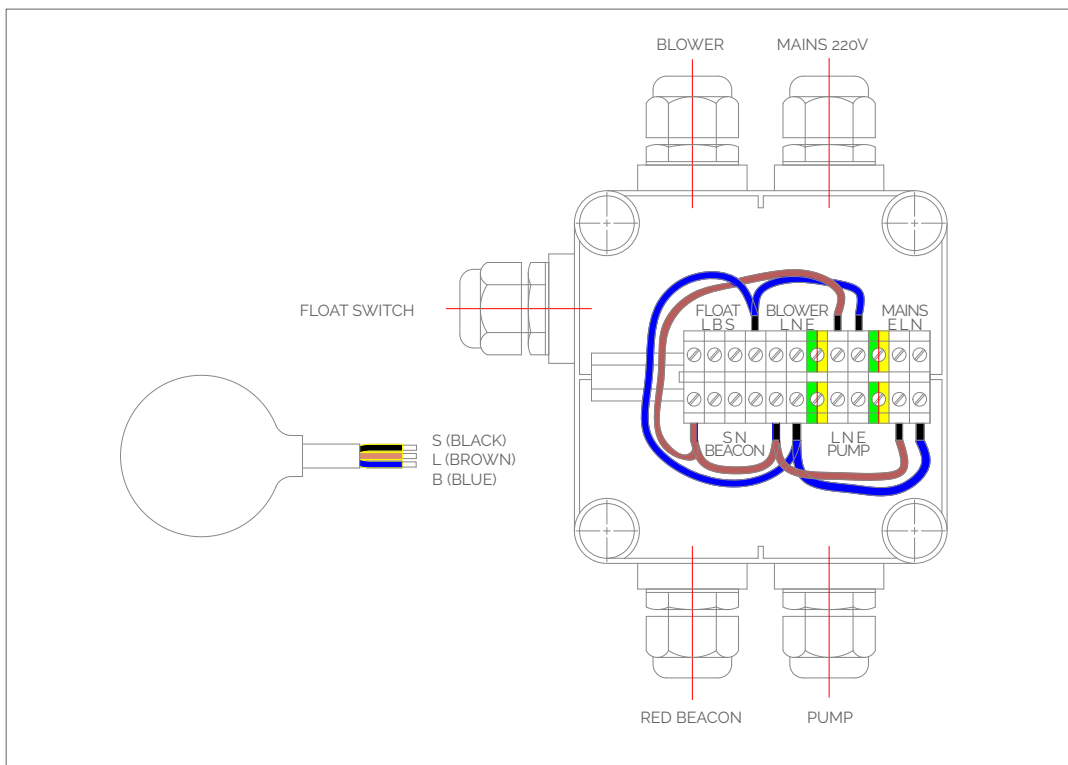

Chamber:

- Ensure that the pump is fully engaged with auto coupling
- Inspect all connections for leaks

Float switch:

- Fill the chamber with clean water, until the float switch is fully covered
- Turn the isolator to the on position
- Check operation of the pump, ensuring that the level in the chamber drops until the float switch stops the pump
- Allow the water level to rise and observe a second start/stop cycle
- Turn the isolator to the off position

High level alarm:

- Fill the tank with clean water, until the float switch and high level alarm are fully submerged
- Turn the isolator to the on position and the red beacon will illuminate
- As the water level drops the high level alarm float tips to indicate the tank is empty, turning off the beacon
- The pump runs until the chamber is at low level
- If the alarm operates with the float hanging down, then it has been wired incorrectly

START UP

Starting the pump:

The pump operates automatically via the combined float switch. Before starting the pump, make sure that:

- The voltage and frequency specified on the pump's nameplate are suitable for the power supply available
- There are no signs of damage to the pump or its power cord
- The electrical connection is made in a dry place, protected against any risk of flooding
- Any extension cables must be suitable for the intended purpose

Pump precautions:

- The pump must never be carried, lifted or made to operate hanging from the power cable
- The pump should not be started more than 20 times in one hour so as not to subject the motor to excessive thermal shock

If you need to know more about the pump specification, please contact WCS Environmental Engineering.

MAINTENANCE

For DMC-EPC models, please ensure the operation and cleanliness of the external pumping chamber is checked during servicing. All servicing and maintenance must be recorded in the accompanying logbook.

Before undertaking any maintenance disconnect the pump from the power supply (i.e. remove the plug from the socket).

These checks must be carried out every 12 months to maintain the efficiency of the system.

Pump precautions:

- Pump power supply should be checked
- Remove pump and check connections
- Make sure all connections are watertight
- Replace all inlet filters

Float switch:

- Check float switch for water ingress
- Check to make sure that the cable is not damaged in any way
- Ensure the switch is operating correctly

TROUBLESHOOTING

DMS-EPC (models with an external pumping chamber)

FAULT	CHECK (POSSIBLE CAUSE)	REMEDY
Pump does not start and makes no noise.	<ul style="list-style-type: none"> A. Check that there is power to pump. B. Check the protection fuses. C. Check the float switch. 	<ul style="list-style-type: none"> A. Check that there is power to pump. B. If fuses are burnt-out, change them. C. Ensure that the float moves freely. Ensure that the float is operating correctly. (Contact the supplier).
Pump does not deliver.	<ul style="list-style-type: none"> A. Inspect base of pump for rag and/or blockages. B. The impeller is worn or blocked. C. The check valve, if installed on the delivery pipe may be compromised. D. The level of the liquid is too low. E. The required head is higher than the pump is designed for. 	<ul style="list-style-type: none"> A. Remove the blockage. B. No serviceable parts in the pump. C. Check that twhe valve is operating correctly and replace if it necessary. D. Adjust the length of the float switch cable. E. Contact WCS Environmental Engineering (See footer)
Pump does not stop.	<ul style="list-style-type: none"> A. The pump is not deactivated by the float switch. 	<ul style="list-style-type: none"> A. Ensure that the float moves freely. Check float operation (the contacts could be damaged - contact the supplier).
Flow is insufficient.	<ul style="list-style-type: none"> A. Check for blockages. B. Ensure that the impeller or the delivery pipe is not partly blocked or encrusted. C. Check three-phase motors for blockages or build-up. 	<ul style="list-style-type: none"> A. Remove any blockage. B. Remove any blockage. C. Check rotation of the motor.
Thermal overload protection stops the pump.	<ul style="list-style-type: none"> A. Check that the liquid to be pumped is not too dense as this could cause the motor to overheat. B. Check that the water temperature is not too high. C. The pump may be partly blocked by impurities. D. The pump is mechanically blocked. 	<ul style="list-style-type: none"> A. Check operation of system i.e. de-sludge air to chamber process. B. Investigate possible cause. C. Carefully clean the pump. D. Check whether there is rubbing between the moving and fixed parts; check the wear of the bearings (contact the supplier).

HINTS & TIPS

It is important that your family, guests and visitors are made aware that your house is connected to a specialist, biological sewage treatment system. They need to know that they should not put anything down the toilet, sinks or drains which could harm the bacteria or block the system.

The Diamond plant is supplied with:

- Building regulations sticker recommend for display in the property
- Logbook which can be replaced, please visit our website for more details

Please ensure you keep a copy of this manual for future reference.

Please keep all information safe and records up to date. It is the responsibility of the plant owner to maintain accurate records and full history of the plant.

THE DO'S & DON'TS GUIDE

Think before you put anything down your sinks, toilets and drains

DO:

- ✓ Only flush the 3 Ps down the toilet - that is pee, poo and paper
- ✓ Try to use cleaning products little and often
- ✓ Try to spread your clothes washing throughout the week
- ✓ Use liquids, not powders in washing machines and dishwashers
- ✓ Use the manufacturers' recommended doses of household cleaning products in your white goods - relevant to the hardness of your local water
- ✓ Ensure your Diamond is subject to regular inspections and servicing

DONT:

- ✗ Pour fat, grease or cooking oil down the sink or drains
- ✗ Frequently change liquid washing, dishwasher and other cleaning products
- ✗ Use salt-based water softeners
- ✗ Use household bleach and strong chemicals indiscriminately
- ✗ Tip bottles of medicine or mouth wash etc. down the sink, toilet or drains
- ✗ Use your waste disposal unit like a rubbish bin - try to use it sparingly
- ✗ Pour any garden chemicals, paint or car engine oil down the sink or drains

PROCESS GUARANTEE AND WARRANTY

Process guarantee

The Process is guaranteed to meet the designed effluent discharge standard for the life of the plant provided that:

- All aspects of the installation manual and user guide operation and maintenance manual are adhered to
- The flows and loads do not exceed those stated on the design sheet (based on industry standards figures, ref BW COP: Flows and loads)
- Grease from commercial kitchens is not present in the influent
- Performance is measured after the process has matured
- Biological inhibitors are not present in the influent
- The system pH is between 7 and 9

Parts covered under the warranty period

WCS Environmental Engineering warrants all the parts in the Diamond plant (when registered with the manufacturer) to be free from defects in material and workmanship in normal use and service.

- WCS Environmental Engineering warrant the tank structure against manufacturing and material defects for 25 years
- The air blowers and kiosk are covered for a period of 2 years
- All warranties start from the date of purchase

WCS Environmental Engineering's sole responsibility under this warranty is limited to repairing, exchanging or replacing any component part or parts that in their judgement show evidence of defects within the warranty period.

If you have a defective part, please contact your maintenance provider.

The defective part or parts must be returned to WCS Environmental Engineering for assessment.

Warranty limitations/exemptions

WCS Environmental Engineering shall not be liable for any labour involved for the removal or replacement of its equipment or the subsequent transportation, handling or packaging of any part or parts thereof.

In no case will WCS Environmental Engineering be liable for loss incurred because of the interruption of service or for consequential damages, labour or expense required to repair defective units, nor shall this constitute a cause for the cancellation of the contract of purchase and sale.

Specifically exempt from this warranty are limited life consumable components subject to normal wear and tear, such as air pump vane, diaphragms and filters.

Chargeable non-warranty work

Service charges incurred (including parts and labour), due to unauthorised alteration, accidental damage, improper use, abuse tampering, failure to follow installation instructions or failure to follow operating and maintenance procedures, are not covered by warranty and are not assumed by WCS Environmental Engineering. All service visits for non-warranty work are chargeable.

Statutory rights are unaffected.

OUR ROOTS

WPL (which is now a part of WCS Environmental Engineering) has been at the forefront of wastewater treatment technology for over 30 years, with international experience of technical design, quality of manufacture and supply of environmental wastewater solutions. Our high level of expertise means that we offer all of our customers, from the individual homeowner to large municipal communities and industrial markets, robust wastewater treatment process solutions that are environmentally compliant.

WCS Environmental Engineering

Unit 1 Aston Road
Waterlooville
Hampshire
PO7 7UX
United Kingdom

Tel: +44 (0)23 9224 2600
Email: enquiries@wcs-group.co.uk
Web: [wcs-group.co.uk/
environmental-engineering](http://wcs-group.co.uk/environmental-engineering)

Disclaimer

WCS Environmental Engineering reserves the right to change specification in line with company policy of improvement through research and development. WCS Environmental Engineering Diamond range is subject to our standard terms and conditions which are available on request.

WCS Environmental Engineering Ltd is a portfolio company of Marlowe PLC.